



AIR SAWS FOR THE PROFESSIONAL



CL50 & CL75
operating instructions

Cengar Air Saw Models CL 50 & 75

We recommend normal safe working practices should be followed as per the Health and Safety at Work Act, or the appropriate National and State Laws. We recommend that eye protection be worn when using Cengar Saws



SPECIFICATIONS

Speed	1200 strokes per minute
Stroke	45 mm
Air Consumption	0.168m ³ /minute
Air Pressure	5-6 Bar
Weight	2.5 Kgs.
Length	400 mm.
Height	135 mm.
Width	40.6 mm.
Vibration Level averaged	3.69 m/s ²
Sound Pressure Level	82.9 db.
Sound Power Level	92.4 db.
Atex Certification	CE II 2G T5 X

LUBRICATION

Use Cengar Green Oil with longer lasting coating properties for best results. Cengar Green Oil is specially prepared to: -

- 1 Emulsify the water generally found in compressed air lines.
- 2 Give perfect mist lubrication.
- 3 Remain fluid at the low working temperature of compressed air tools.
- 4 Contains corrosion and oxidation inhibitors.

Incorrect oils if used will soon “break down” forming a sludge which will slow and eventually stop the action of the saw. See maintenance details.

INSTALLATION OF BLADES.

Before attempting to insert or change a blade, ensure that the air supply is isolated by operating the isolation valve provided. Loosen the retaining grub screws with the key provided, insert blade through nosepiece so that the teeth are cutting on the pull stroke.

Locate the back screw in the hole in the end of the blade, for a positive drive, the front screw can then be tightened to grip the blade firmly.

BLADES

Cengar “Shatterproof” Bi-Metal blades are specially prepared for use with Cengar saws, to withstand the high operating speeds, and give maximum cutting life.

Choose the teeth per inch to suit the characteristics of the material being cut.

Choose pitch to ensure that at least 3 or 4 teeth are cutting at the same time.

OPERATING THE SAW

We recommend that eye protection be worn, and normal safe working practices observed as per the Health and Safety at work act, and the appropriate National and State Laws.

Set the isolator to “on” position, rest the blade on the material to be cut with the nosepiece firmly abutted to the work piece, with forward hand pressure, to prevent judder. Allow the Cengar Saw to cut under its own weight, with just a slight downward hand pressure to keep the teeth engaged in the cut. It is not necessary to put excessive downward pressure on the saw, this only accelerates blade wear, and prevents the saw from operating efficiently. Normal airline pressure of 5 to 6 Bar is required , any higher pressure only accelerates internal wear of the machine.

USE IN HAZARDOUS AREAS

We strongly advise that the contact area of the blade on the work piece be quenched with coolant or water during cutting to dissipate any heat which may be created by the cutting process.

Anti-static conductive air hose must be used, with adequate earth bond continuity (resistance below 1 ohm), to ground any electrostatic charges.

MAINTENANCE AND GENERAL HINTS

Always ensure sufficient oil in the tool, especially when the saw is in constant use.

The valve unit part no. 1139 is a vital component manufactured to close tolerances, and will not tolerate abusive treatment. Lubrication is essential. Any neglect will seriously affect performance of the saw, causing the saw to stall intermittently, or stop completely.

Very little maintenance is required if the correct oil is used, but incorrect oil will soon breakdown into sludge, slowing down the action of the saw, necessitating its removal by use of Cengar M.S. Cleaner. It is imperative that the saw is re-oiled immediately after cleaning, with Cengar Green Oil.

CL 50 & 75 Exploded

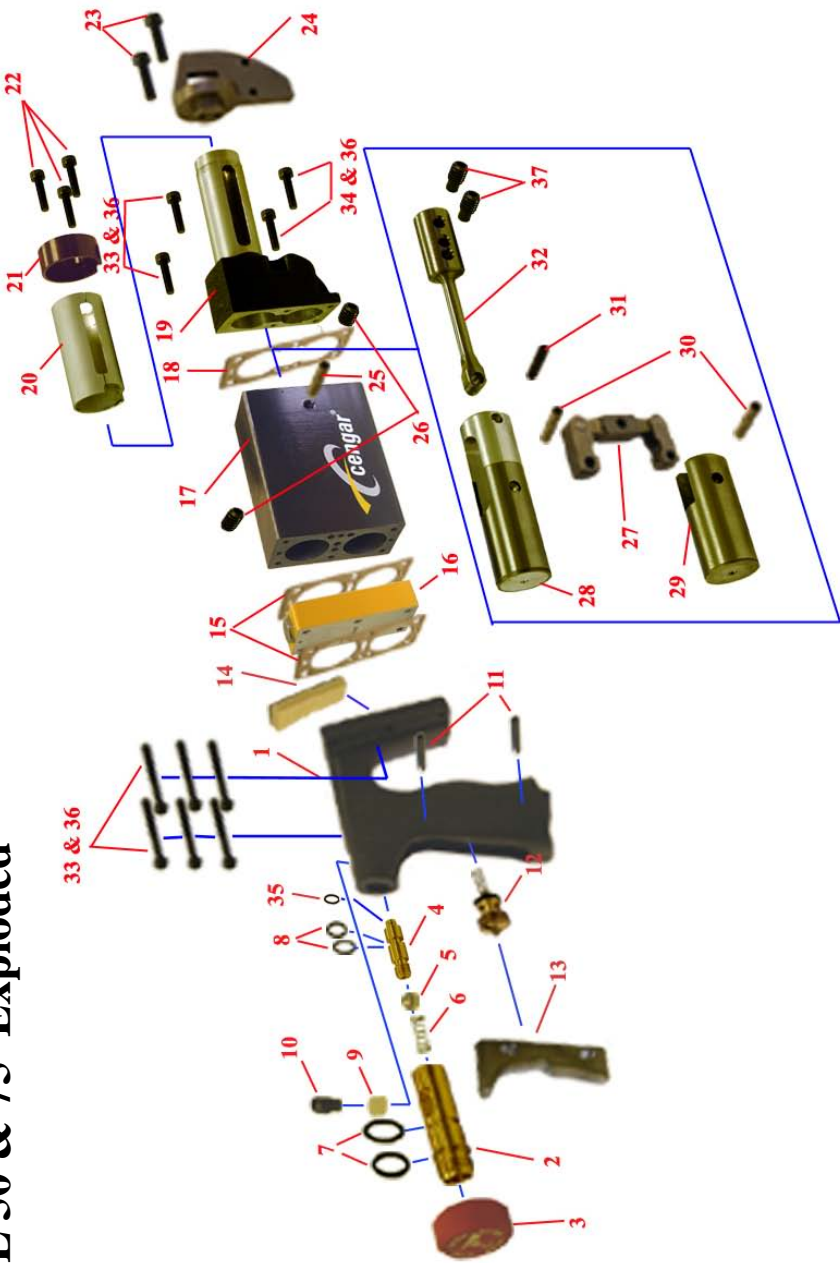

Item	Part No.	Description	Number Per Tool	Item	Part No.	Description	Number Per tool
1	9550	Handle	1	19	1143	Front end complete	1
2	9554	Isolator body	1	20	1144	Silencer Guard	1
3	9553	Oil Cap	1	21	1143A	Front End Cap	1
4	9555	Isolator Nozzle	1	22	54160	Front cap screws	3
5	9559	Oil Control Ball	1	23	54160	Screws—Nosepiece	2
6	9334A	Spring	1	24	5045/5075	Nosepiece(1/2"-3/4")	1
7	9561	•O• Ring Large	2	25	1147	Centre Shaft	1
8	9560	•O• Ring Small	2	26	55516	Screws for above	2
9	9557	Détente Spring	1	27	1150	Link to Pistons	1
10	9556A	Lock Screw	1	28	1148	Top Piston	1
2 to 10	9552	Isolator Assembly		29	1152	Bottom Piston	1
11	51834	Roll Pin-Trigger	2	30	1147	Pin to Link	2
12	50034	Valve in Handle	1	31	1147	Pin to Pedestal	1
13	9502	Trigger	1	32	1153-5	Pedestal	1
14	9506	Filter/Gauze	1	33	53112	Screw-Handle/Front	8
15	9538	Gasket	2	34	53034	Screw-Front Lower	2
16	1139	Valve Unit	1	35	QR5108	Quad Ring	1
17	1141	Body	1	36	W55	Serrated Washer	10
18	1142	Gasket—Front end	1	37	54516	Screw-Blade Grip	2

IF THE SAW DOES NOT OPERATE

- 1 Check that the isolator is switched on.
- 2 Check air supply is correct.
- 3 Valve in handle (part no. 50034) could be worn and/or the seal is broken, blocking an air passage. Check and replace if necessary.
- 4 Valve unit (Part No. 9507) may be stuck. **IT IS IMPERATIVE TO REMOVE THE SAW FROM THE AIRLINE BEFORE COMMENCING THIS CHECK.** Remove the two hexagonal nuts, push out valve piston with a pencil, keeping note which end is top. Clean with oil only, NEVER USE ABRASIVE. Clean valve bore with oil, re-fit piston from top, keeping the seal at the top end. Tighten nuts and reconnect saw to air supply.

REPLACEMENT OF PISTONS ON CL 50 & CL 75 SAWS

- 1 The old pistons must be removed through the front of the body (blade end) after removing handle and front, push the top piston forward (bottom piston rearward) this will bring the link shoulders clear of the cylinder walls.
- 2 Remove the centre shaft, by firstly removing the two retaining screws (Part No. 55516) and pushing the shaft out carefully.
- 3 Push the top piston forward, (the bottom piston will follow) until everything comes out.
- 4 Before refitting, ensure that each piston is a smooth sliding fit in it's own bore, without being able to feel slackness.
- 5 Insert the pistons in to the bores from the front, in the same staggered relationship as during removal, to ensure that the link does not damage the cylinder bores.
- 6 Refit the centre shaft and securing screws, using a thread lock adhesive on the screws.
- 7 Check that the pistons slide smoothly over the full travel, without sticking.

REPLACEMENT OF ISOLATOR ASSEMBLY

All the parts of the isolator are available separately, however for ease of service, we offer an **isolator assembly (Part No 9552)** complete with retaining screw and détente spring, this has the seat bonded in place already, and can be fitted in seconds.

PIPE CUTTING WITH THE CL50 & 75

A clamp kit can be fitted to the CL saws, (Part No CCSG3) allowing the machine to mount on pipes and sections.

To fit the parts required on the saw: -

1. remove the nosepiece and silencer
2. Fit the carrier over the front end tube, all the way to the back, and clamp tight with the Allen key provided.
3. Slide on the new shortened silencer, and refit the nosepiece.

The clamp carrier can remain on the saw for normal use when the clamp is not in use.

Always remove the saw from the airline before commencing any maintenance work.

Only fit genuine Cengar parts and accessories, or safety may be compromised

NEVER

- 1 **NEVER** hold the Cengar saw in a vice by the body, this will distort the bores, rendering the tool inoperative.
- 2 **NEVER** screw nameplates to the body, as the screws may penetrate an airway or bore.
- 3 **NEVER** operate the Cengar saw without lubrication.
- 4 **NEVER** be tempted to clean internal parts with anything other than a clean lint free cloth, and M.S. Cleaner, or Cengar Green oil.

ALWAYS

- 1 **Always** use Cengar green oil for best results. Keeping the saw clean and well oiled will give excellent reliability, and a long life.
- 2 **Always** use Cengar Bi-Metal Shatterproof blades, for safety, and best cutting performance
- 3 **Always** isolate the air supply when changing blades.
- 4 **Always** wear eye protection when using sawing machines.

ACCESSORIES

Saw Blades



MC 220/24	12 mm deep blade for general cutting 24 TPI
MB 150/??	150 mm long x 19 mm blade, pitches 10, 18, or 24
MB 200/??	200 mm long x 19 mm blade, pitches 10, 18, or 24
MB 250/??	250 mm long x 19 mm blade, pitches 10, 18, or 24
MB 300/??	300 mm long x 19 mm blade, pitches 10, 18, or 24

Other sizes and types available on request

Cengar Green Oil



GO 9107P	Cengar Green Oil 250 ml plastic bottles for all air tools
GO 9109	As above in 5 litre container
GO 9110	As above in 25 litre container

M.S. Cleaner

MS 9105	1 litre General purpose cleaning fluid for air tools. Always use plenty of Cengar green oil afterwards.
---------	--

Nosepiece

5045	Replacement nosepiece/blade guide for 12 mm deep blades
5075	Alternative nosepiece/blade guide for 19 mm deep blades

SERVICE

We offer a full factory repair and refurbishment service for Cengar Saws, - normally within 5 working days. Quotations at no charge can be given before work is carried out.

DISTRIBUTOR ADDRESS

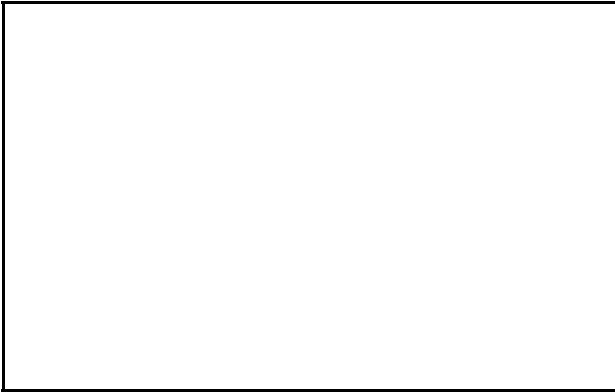

Cengar Universal Tool Co. Ltd.
70 Lister Lane
Halifax, England . HX1 5DN
Tel: 01422 354626 Fax: 01422 349024
enquiries@cengar.com
www.cengar.com