



Nencki equipment for rail welding plants

Nencki

From individual machines to complete solutions

Nencki offers complete solutions for machines for long rail welding plants, including rail conveyor systems and superior controls for the process flow. With a complete range of equipment for producing long rails, Nencki has optimal solutions for specific customer requirements.

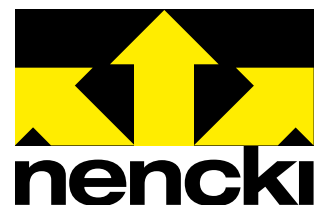

Rail processing

Complete rail welding plant from Nencki

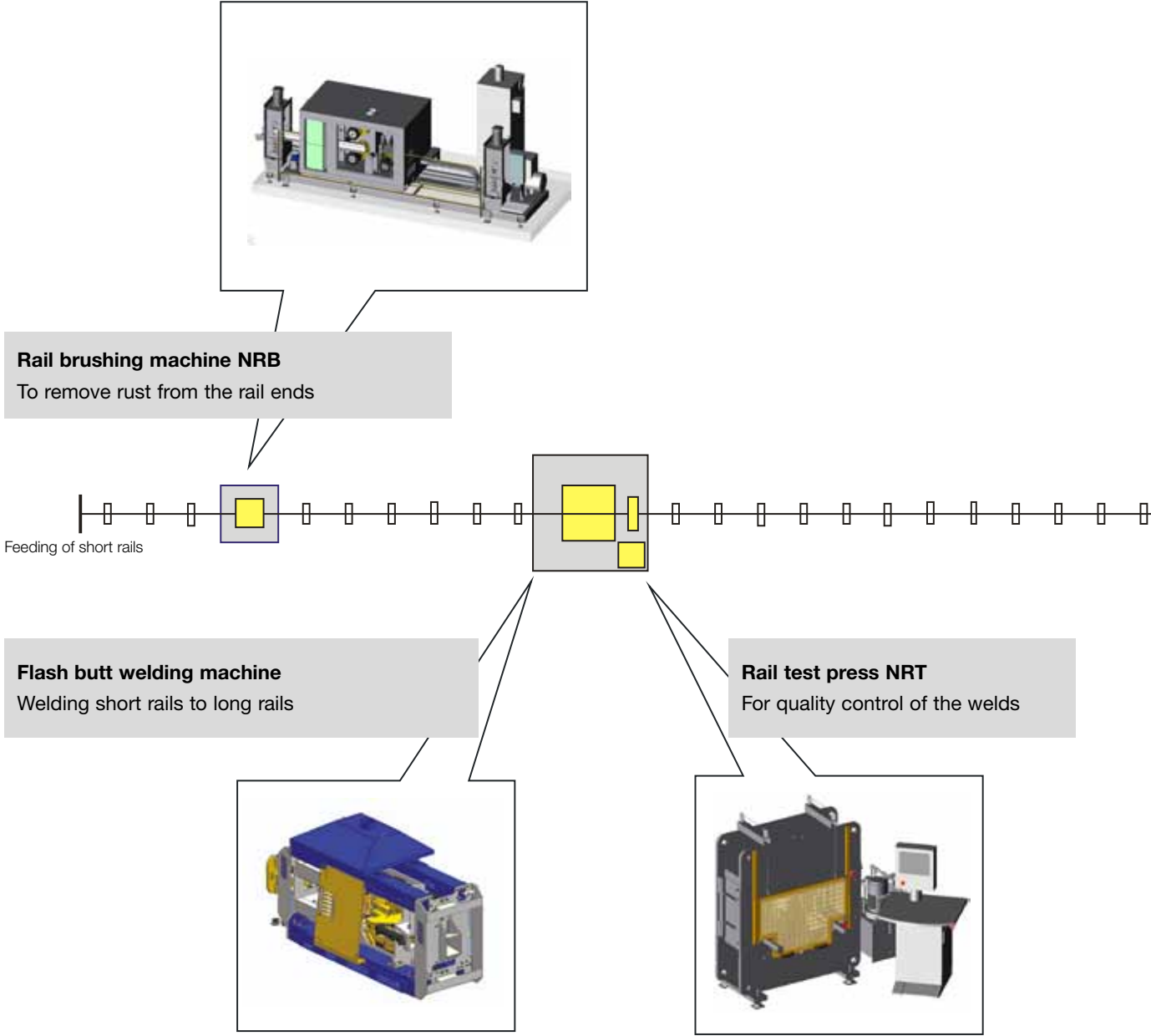

Rail cooling NRC

Cooling of rails for the further process

Final check by external measuring system or ultrasonic testing

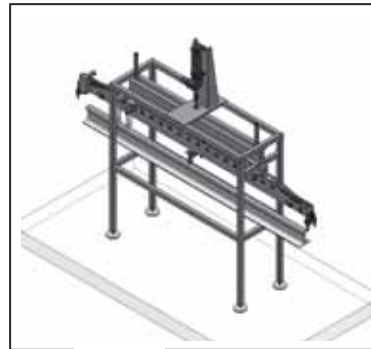
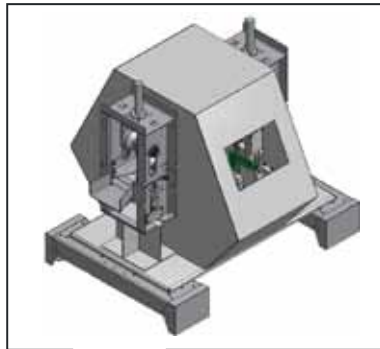
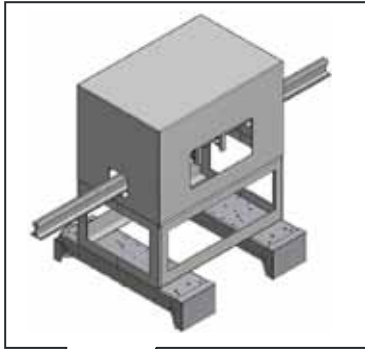

Rail milling machine NRM

To remove weld burr on the bottom of the rail foot

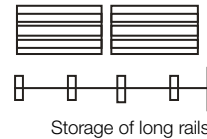

Storage of long rails

4-way straightening press NRS

Alignment in horizontal and vertical direction

Rail grinding machine NRG

To remove weld burr on the rail head



Rail profiles up to UIC68

Short rails: 10 m, 25 m, 50 m, 100 m, etc.

Long rails: 200 m, 250 m, 500 m, etc.





Railway technology Plant technology Vehicle technology Manufacturing Service

Nencki Ltd. offers a comprehensive customer and spare parts service in Switzerland but also through international representatives.

Nencki Ltd.
Gaswerkstrasse 27
CH-4901 Langenthal, Switzerland
Phone +41 (0)62 919 93 93
Fax +41 (0)62 919 93 90
Email railway@nencki.ch
www.nencki.ch/railway

